

Rate this article: ★★★★★
Your Current Vehicle: 2008 Honda Fit

Shock Absorber Removal and Installation

NOTE

Applicable vehicles:

- 2007-08 Honda FIT

Rear Damper Replacement

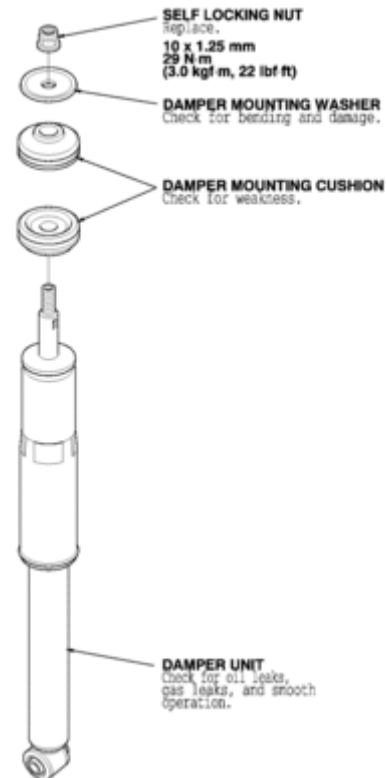

Exploded View

Feedback

[Click to Enlarge](#)

Removal

- Raise the rear of the vehicle, and support it with safety stands in the proper locations.
- Remove the rear wheel.
- Position the floor jack under the axle beam (A). Raise the floor jack until the rear suspension begins to compress.

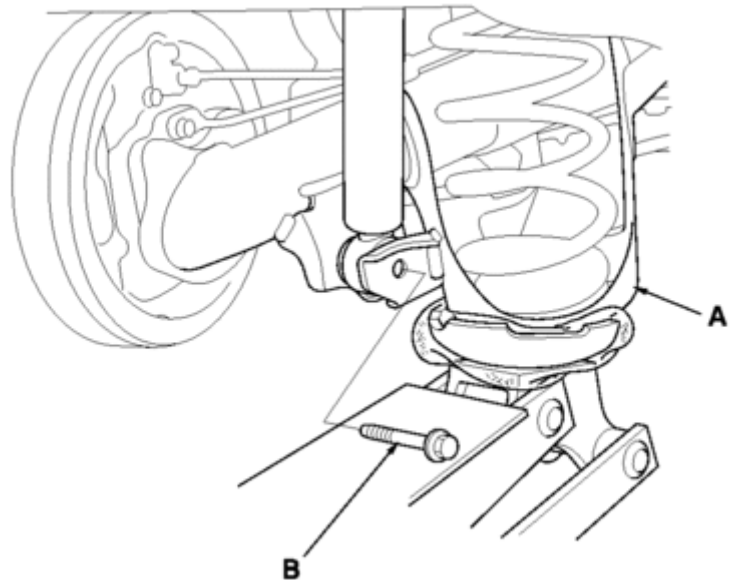

[Click to Enlarge](#)

- Remove the flange bolt (B) from the rear damper.
- Remove the lid (A) from the trunk side trim.

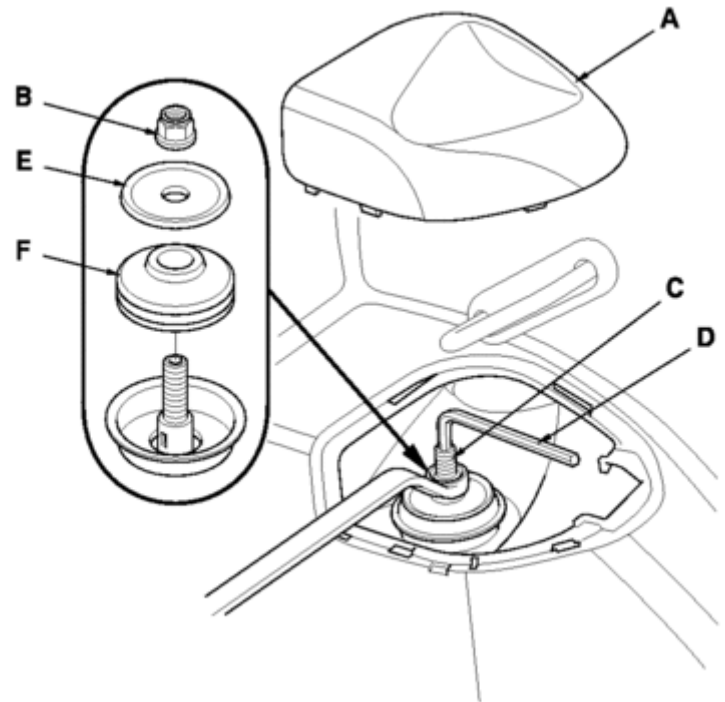

Click to Enlarge

- Remove the self-locking nut (B) while holding the damper shaft (C) with a hex wrench (D).
- Remove the damper mounting washer (E) and the damper mounting cushion (F) from the top of the damper.
- Compress the damper unit (A) by hand, and remove it from the vehicle. Be careful not to damage the body.

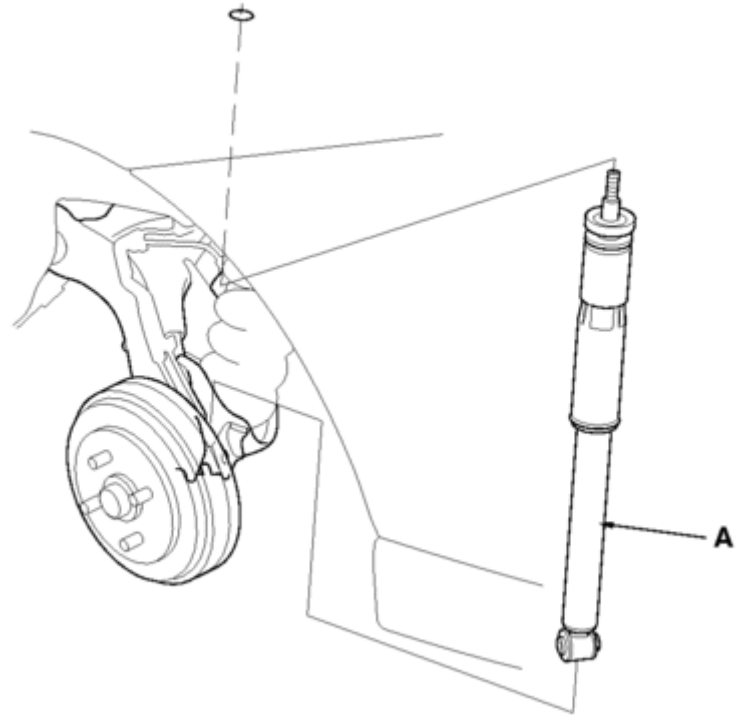

Click to Enlarge

Inspection

- Install the 10 mm flange nut on the damper shaft end, and set the socket wrench and T-handle on the nut.
- Compress the damper assembly by hand, and check for smooth operation through a full stroke, both compression and extension. The damper should extend smoothly and constantly when compression is released. If it does not, the gas is leaking and the damper should be replaced.

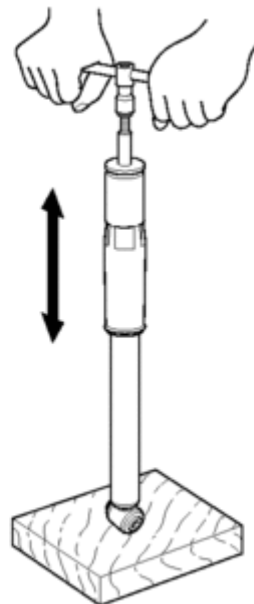

Click to Enlarge

- Check for oil leaks, abnormal noises, or binding during these tests.

Installation

- Install the damper mounting rubber (A) onto the damper unit (B). Compress the damper by hand, and move it into position. Be careful not to damage the body.

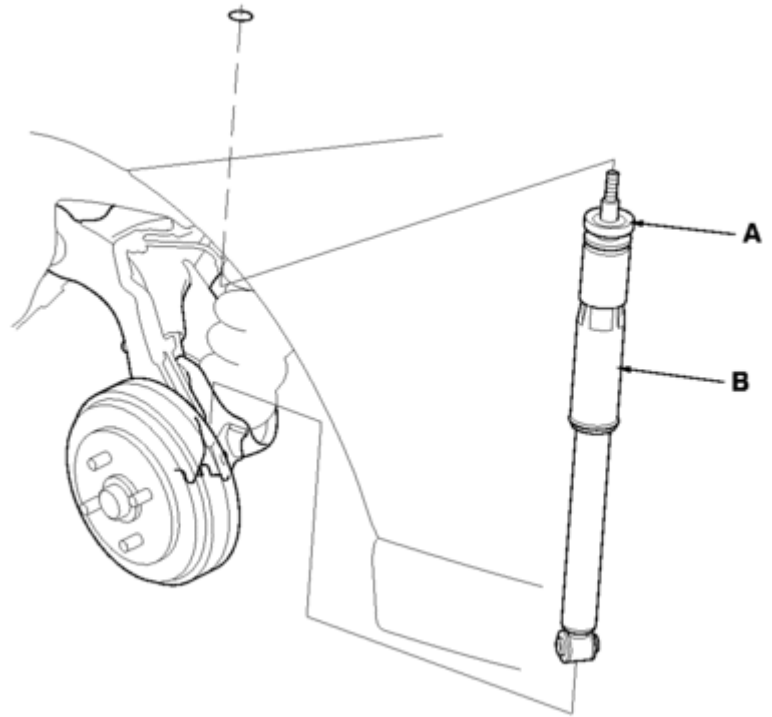

Click to Enlarge

- Position the floor jack under the axle beam.

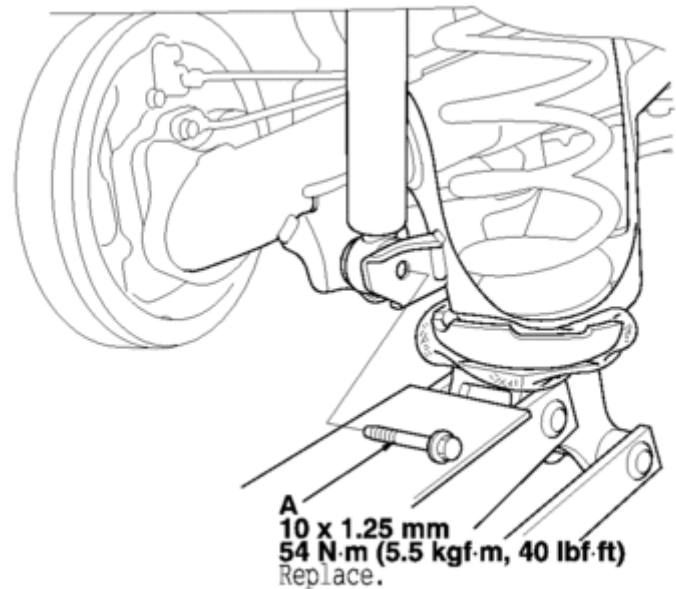

Click to Enlarge

- Slowly raise the floor jack until you can align the bolt hole with the holes in the axle beam and the damper, then loosely install the new flange bolts (A).

- Raise the rear suspension with the floor jack until the vehicle just lifts off the safety stands, then tighten the flange bolt to the specified torque value.
- Install the damper mounting cushion (A), the damper mounting washer (B), and a new self-locking nut (C) on the damper shaft.

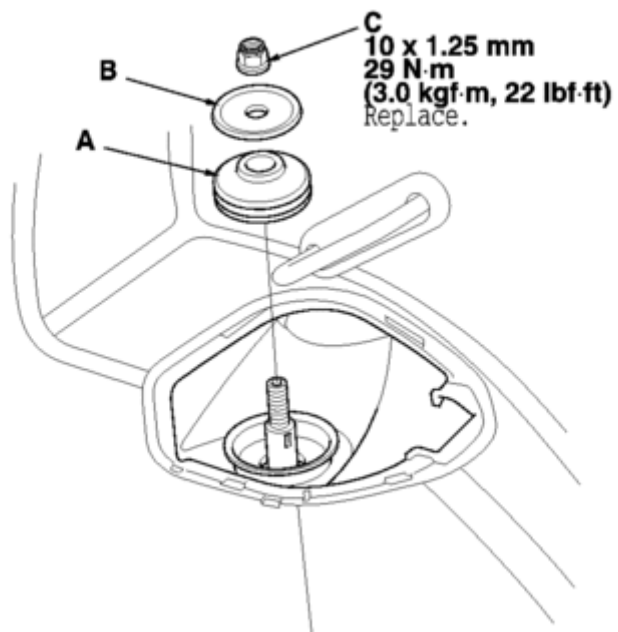

Click to Enlarge

- Tighten the self-locking nut to the specified torque value while holding the damper shaft (A) with a hex wrench (B).

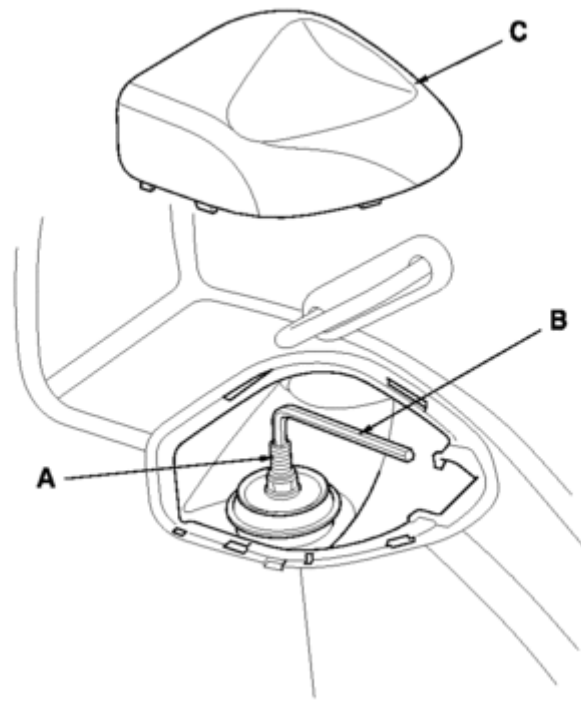

Click to Enlarge

- Install the lid (C) on the trunk side trim.
- Clean the mating surface of the brake drum and the inside of the wheel, then install the rear wheels.
- Check the wheel alignment, and adjust it if necessary.

Copyright ©2019 by Chilton, an imprint of Cengage Learning

[\(//lh/Home/Index/mwellLne7NwdSu0dEvfb2M51ATxi-lqkUwtxwgYdDwfy7qIM1\)Home](#)

[Terms and Conditions \(//www.cengage.com/content/footer/terms_of_use.aspx\)](#)

[Privacy Statement \(//www.cengage.com/content/footer/privacy_statement.aspx\)](#)

[Contact Us \(//www.cengage.com/contact/\)](#)



Feedback