

MasterSheet

022 0052
Revision 04/01/14



Complete Car Audio Installation Instructions **CRUTCHFIELD**

IMPORTANT

Before starting, compare items on your invoice with items received. Carefully check through packaging material. If any item is missing, please call **Crutchfield Technical Support at 1-800-955-9094**.

Although reasonable attempts are made to verify the accuracy of the information contained in this MasterSheet, it is presented without warranties or guarantees of any type due to the constantly changing nature of this type of information and running changes in vehicle production. Any person or entity using this information does so at his or its own risk. If you find our instructions are different from your vehicle, or if you have questions, do not continue with your installation. Contact our toll-free technical support for assistance.

Inside...



0000220052

Page

2	Factory Radio Removal			✓	✓	
3	OEM Integration					
4	Receiver Installation			✓		
5	Dash Speakers (Tweeters)		✓			
6-7	Front Door Speakers	✓			✓	
8-9	Rear Door Speakers	✓			✓	
10	Wire Splicing Guide					✓

Tools Required ▶

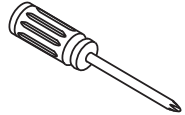
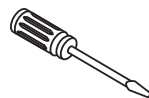
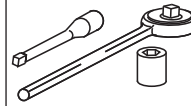
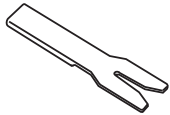
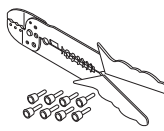
Phillips Screwdriver	Small Flat Blade Screwdriver	8mm Socket, Ratchet & Extension	Panel Tool	Wire Stripper & Crimp Caps
				

Note: At this time, no aftermarket antenna is available from Crutchfield. A replacement antenna may be purchased from a local dealership.

CRUTCHFIELD
Copyright 2014 Crutchfield Corporation

022 0052

Factory Radio Removal

1. Before proceeding, eject disc(s) from factory unit if present.
2. Set parking brake and disconnect negative battery cable to prevent any electrical short.
3. Pry off cover panel above power outlet on dash and release clips to remove (Figure 1).
4. Remove one (1) 8mm screw exposed by removal of cover panel (Figure 2). **Note:** Dropping glove box door will provide a better view of this screw.
5. Pry out sides of receiver trimpanel to release eleven (11) clips. Disconnect wiring harnesses and remove factory radio assembly (Figures 3, 4 & 5).

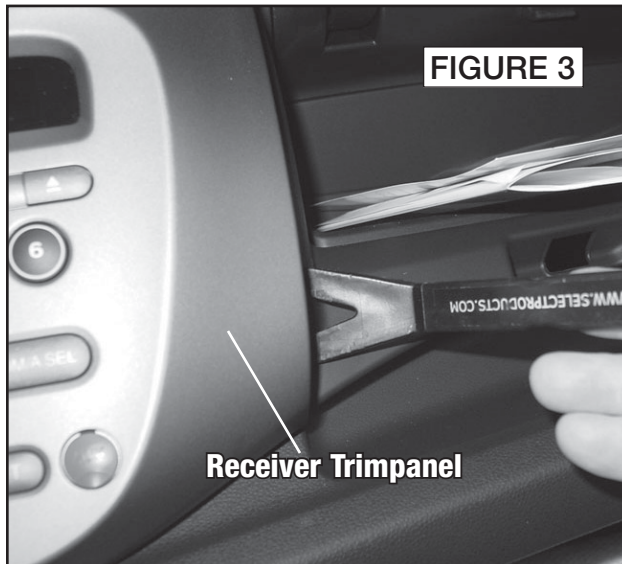
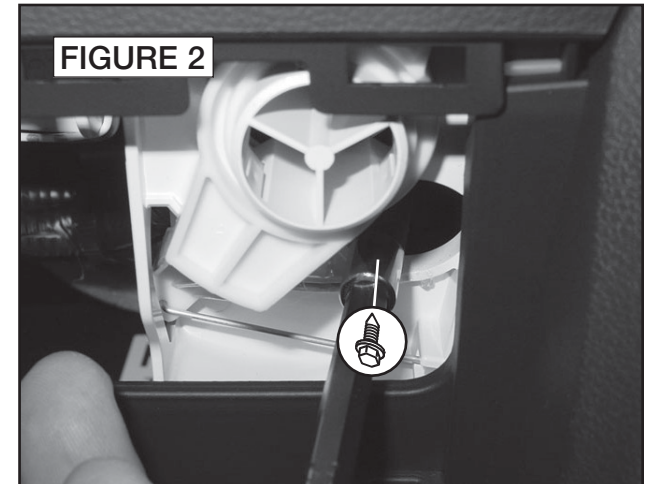

 1-800-955-9094
TECHNICAL SUPPORT

CRUTCHFIELD[®]
Copyright 2014 Crutchfield Corporation 2

022 0052

OEM Integration

This page addresses integrating aftermarket accessories such as CD Changers, Auxiliary Input Adaptors, iPod® Adaptors, etc., with a factory radio system.

1. Remove factory radio following instructions on the previous page.
2. Follow instructions supplied with the accessory device.
3. Connect optional adaptor to inputs as shown.
4. Test operation of the adaptor and reassemble dash by reversing removal steps.

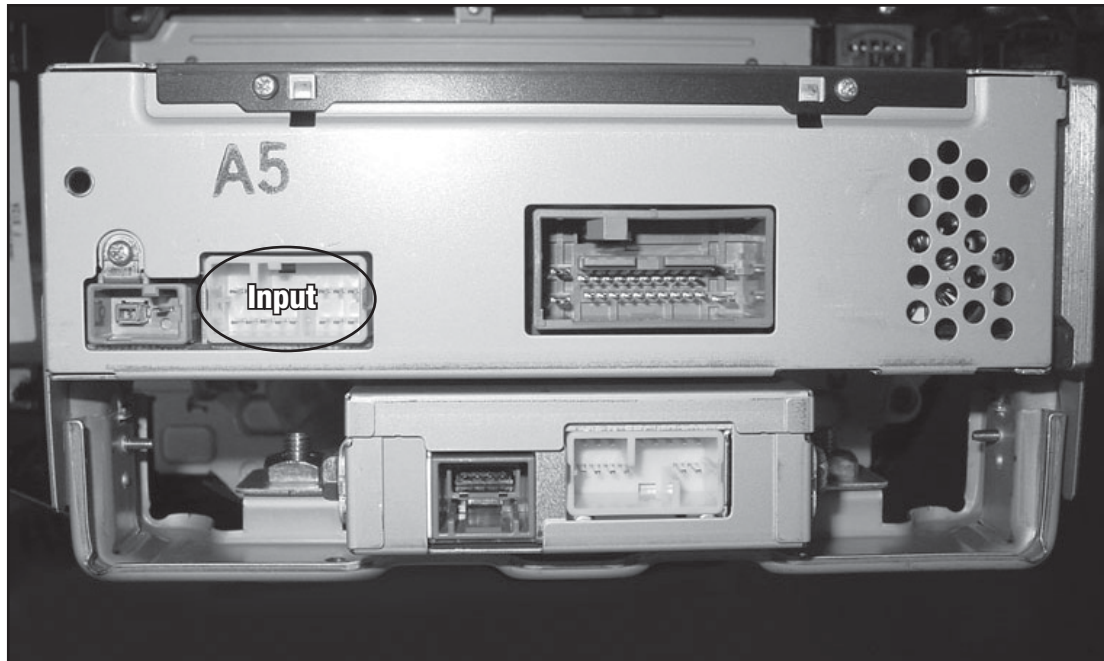

Rear View Factory Radio



1-800-955-9094
TECHNICAL SUPPORT

022 0052

Receiver Installation

A Standard DIN unit is shown. A Double-DIN receiver may also be installed following these same instructions.

1. Secure receiver to mounting bracket following instructions supplied with the installation kit.
2. Make wiring connections following instructions supplied with the receiver wiring adaptor received from Crutchfield.
3. Hold receiver assembly near dash. Connect receiver wiring adaptor to vehicle harness and plug antenna lead into rear of receiver.
4. Slide assembly into dash until it snaps into place.
5. Test operation and reassemble dash by reversing removal steps.

NOTES:

Please read first

- *Inspect factory receiver harness connector in vehicle. Ensure that the wiring adaptor received from Crutchfield plugs into the vehicle's connector. If the connector is missing or incorrect, please call our **Technical Support Department** at **1-800-955-9094**.*



1-800-955-9094
TECHNICAL SUPPORT

CRUTCHFIELD®

Copyright 2014 Crutchfield Corporation 4

Dash Speakers (Tweeters)



IMPORTANT

No speaker adaptor bracket is available at this time from Crutchfield for this speaker location. It will be necessary to fabricate a mounting bracket in order to install an aftermarket speaker.

No speaker wiring adaptor is available for this location. It will be necessary to splice wires to make connections.

It is possible that the replacement speakers do not have screws supplied. It may be necessary to acquire mounting hardware.

1. Using the pry point near the windshield, pry up tweeter/grille assembly to release three (3) clips. Disconnect wiring harness and remove assembly (Figures 1 & 2).
2. Pry tweeter out of grille to release three (3) tabs and remove tweeter.
3. Fabricate a speaker mounting bracket and secure new speaker to bracket.
4. Make wiring connections following instructions on page 10. Return to this page to complete installation. Secure speaker/bracket assembly to grille.
5. Install tweeter/grille assembly and test operation.

NOTES:

Please read first

- Instructions show factory size speakers or speakers with adaptor brackets only. Cutting or fabricating (not shown) will be required for other speaker sizes.

FIGURE 1



FIGURE 2



022 0052

Front Door Speakers

NOTES:

Please read first

- Instructions show factory size speakers or speakers with adaptor brackets only. Cutting or fabricating (not shown) will be required for other speaker sizes.



IMPORTANT

It is possible that the replacement speakers do not have screws supplied. It may be necessary to acquire mounting hardware.

1. Remove one (1) phillips screw behind door release (Figure 1).
2. Pull door release trim toward the front of the vehicle to release, but do not remove (Figure 2).
3. Push in three (3) clips along bottom of armrest, then pull off armrest cover to remove (Figures 3, 4 & 5).
4. Remove one (1) phillips screw exposed by removal of lower armrest cover (Figure 6).

Continued on the next page.

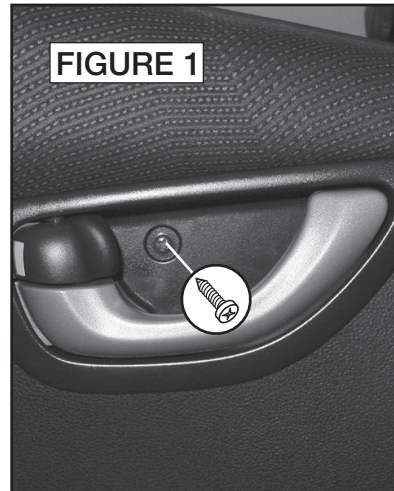

FIGURE 1

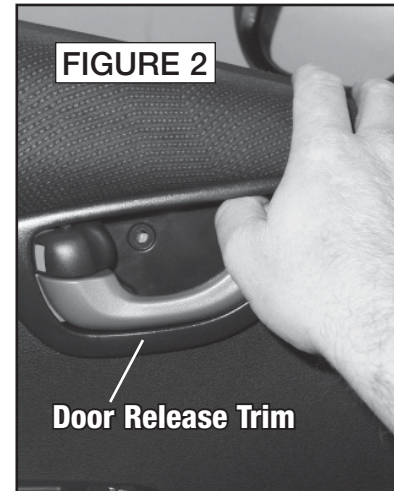

FIGURE 2

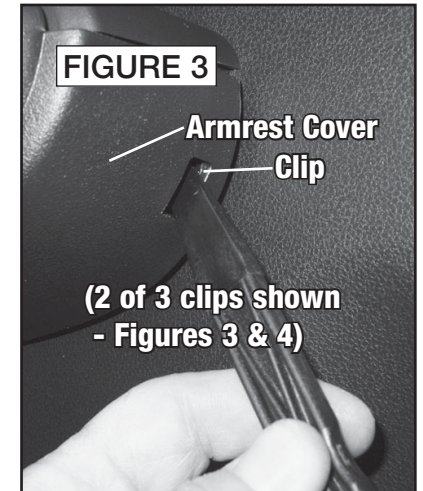

FIGURE 3

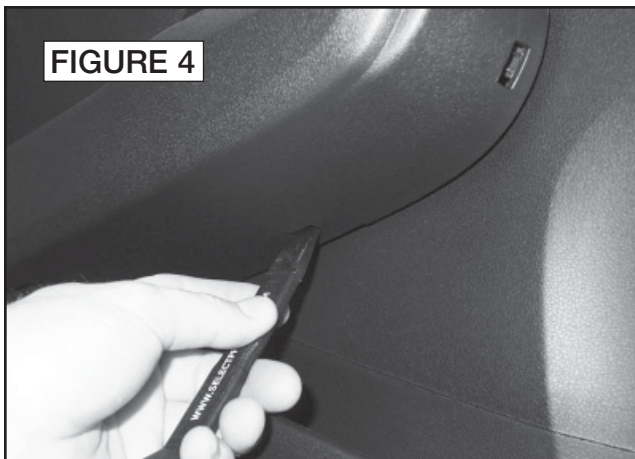

FIGURE 4

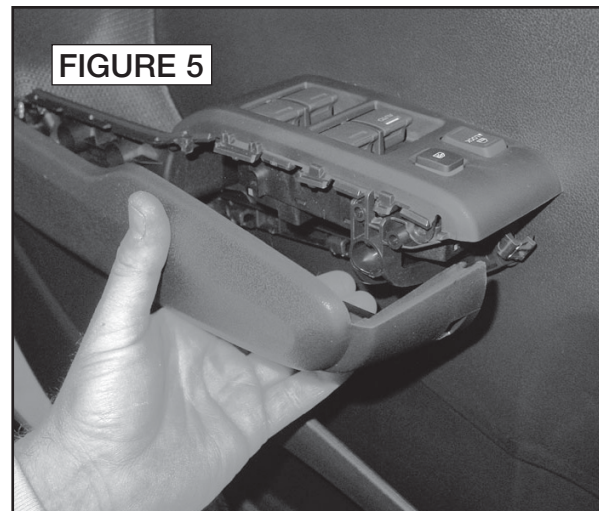

FIGURE 5

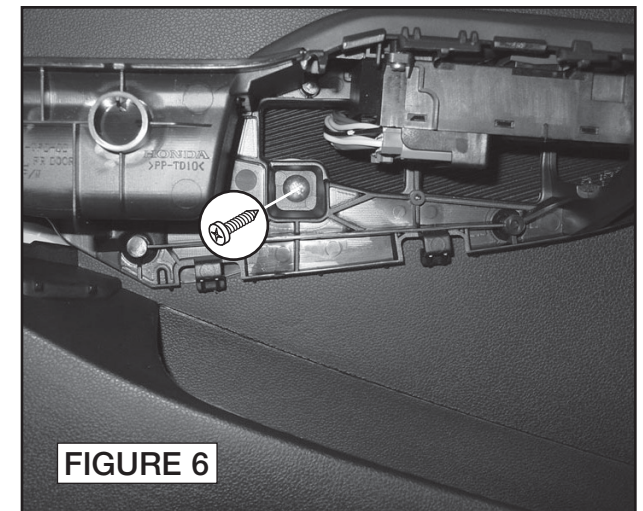

FIGURE 6



1-800-955-9094
TECHNICAL SUPPORT

CRUTCHFIELD

Copyright 2014 Crutchfield Corporation 6

Front Door Speakers (continued)

5. Pry out sides and bottom of door panel to release seven (7) clips. Work release handle assembly through opening in door panel. Disconnect wiring harness and remove door panel (Figure 7).
6. Remove one (1) phillips screw securing speaker to door. Lift speaker to release, disconnect speaker wiring harness and remove speaker (Figure 8).
7. Secure new speaker to adaptor bracket.
8. Connect speaker wiring adaptor of replacement speaker to vehicle speaker harness. Secure speaker/bracket assembly to door with screw previously removed.
9. Test speaker operation and reinstall door panel by reversing removal steps.

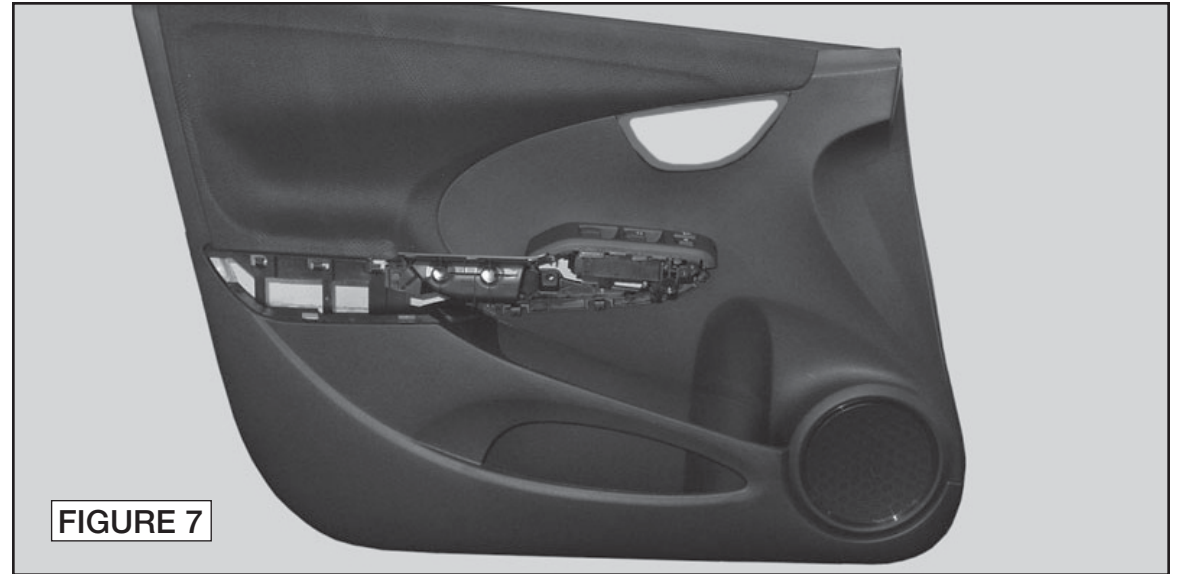

FIGURE 7



FIGURE 8



SAFETY CHECK

- Check that wires do not interfere with window operation.
- Test door lock and release operation.



1-800-955-9094
TECHNICAL SUPPORT

CRUTCHFIELD[®]
Copyright 2014 Crutchfield Corporation

022 0052

Rear Door Speakers

NOTES:

Please read first

- Instructions show factory size speakers or speakers with adaptor brackets only. Cutting or fabricating (not shown) will be required for other speaker sizes.



IMPORTANT

It is possible that the replacement speakers do not have screws supplied. It may be necessary to acquire mounting hardware.

1. Starting at the front edge, pull "sail" panel to remove (Figure 1).
2. Remove one (1) phillips screw behind door release (Figure 2).
3. Pull door release trim toward the front of the vehicle to release, but do not remove (Figure 3).
4. Push in three (3) clips along bottom of armrest, then pull off armrest cover to remove (Figures 4 & 5).
5. Remove one (1) phillips screw exposed by removal of lower armrest cover (Figure 6).

Continued on the next page.

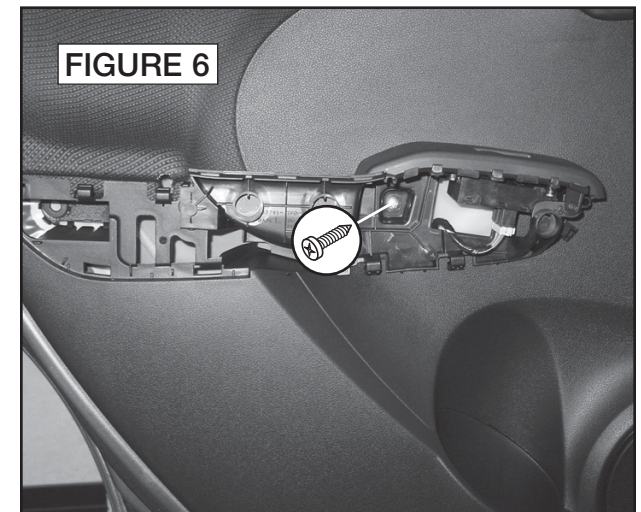
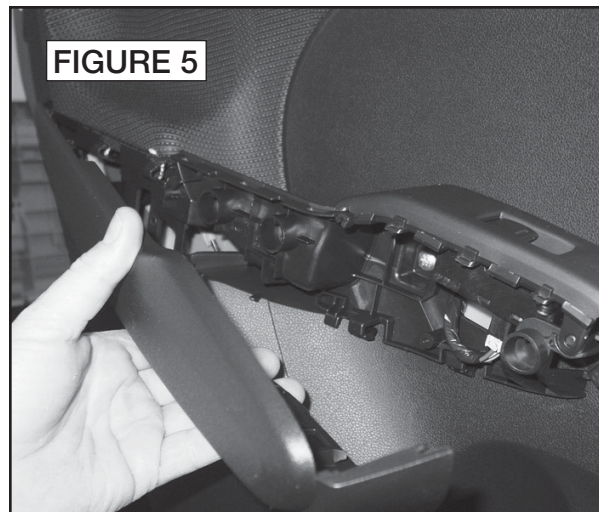
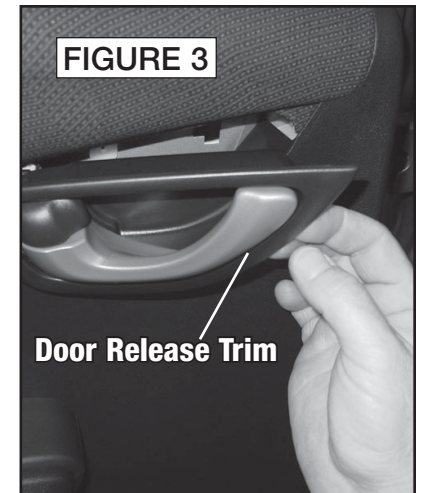
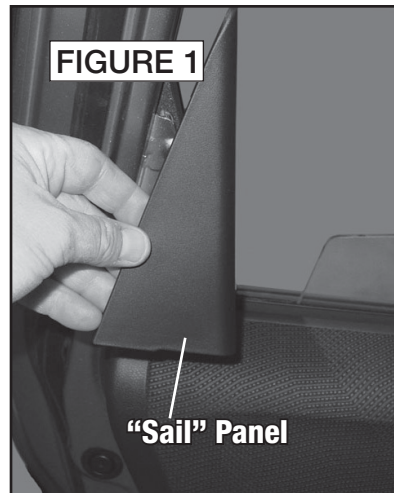
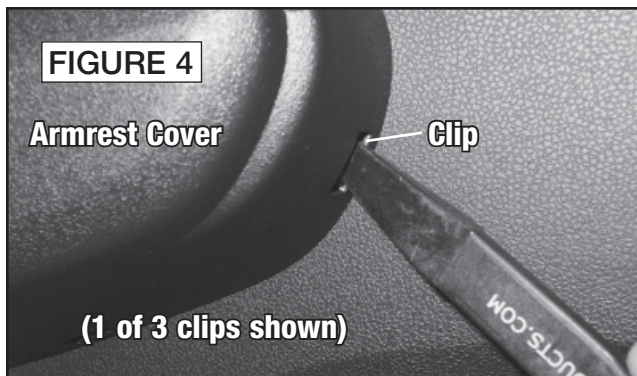

1-800-955-9094
TECHNICAL SUPPORT

CRUTCHFIELD
Copyright 2014 Crutchfield Corporation

Rear Door Speakers (continued)

6. Pry out sides and bottom of door panel to release six (6) clips. Work release handle assembly through opening in door panel. Disconnect wiring harness and remove door panel (Figure 7).
7. Remove one (1) phillips screw securing speaker to door. Lift speaker to release, disconnect speaker wiring harness and remove speaker (Figure 8).
8. Secure new speaker to adaptor bracket.
9. Connect speaker wiring adaptor of replacement speaker to vehicle speaker harness. Secure speaker/ bracket assembly to door with screw previously removed.
10. Test speaker operation and reinstall door panel by reversing removal steps.

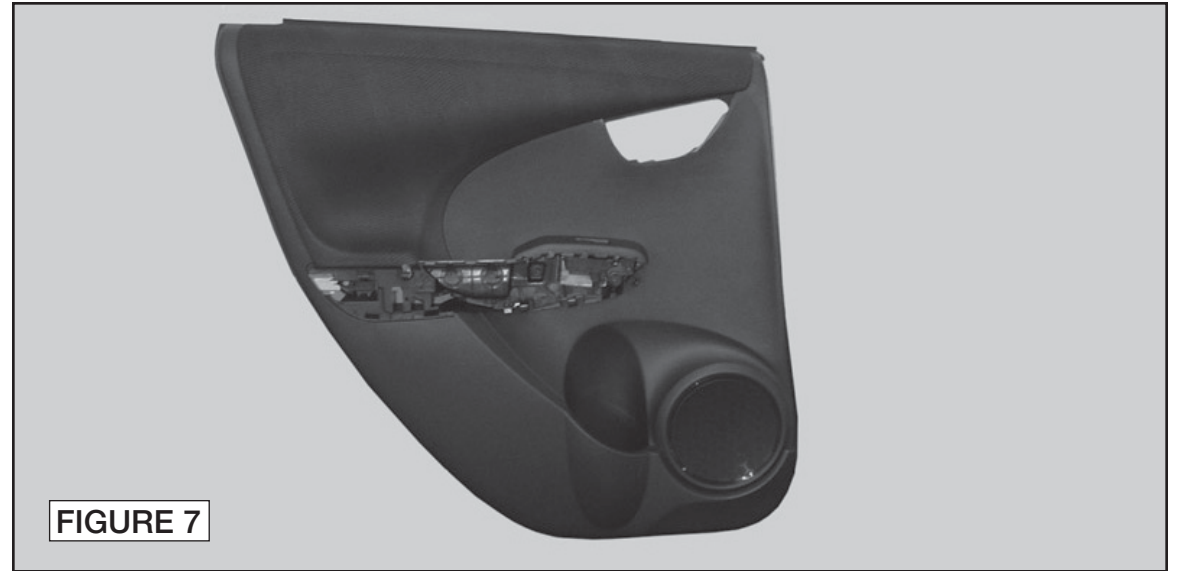

SAFETY CHECK

- Check that wires do not interfere with window operation.
- Test door lock and release operation.



Wire Splicing Guide

These methods can be used to make wiring connections if no receiver or speaker wiring adaptor is available.

CRIMP METHOD

Factory harness is removed. Save harness if it is to be reconnected in the future by this method.

1. Cut factory wires behind factory speaker harness.

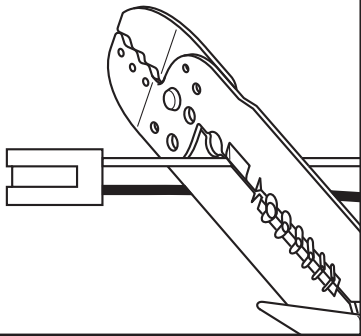

2. Strip end of each wire back 1/2".

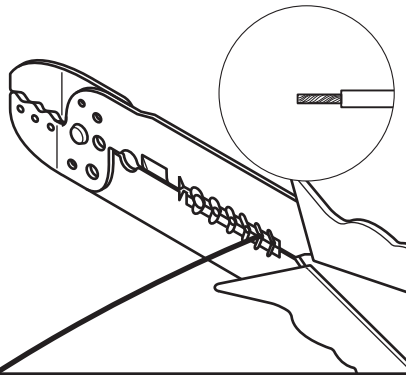

3. Twist each positive pair of wires together and insert in crimp cap. Repeat step for negative wires.

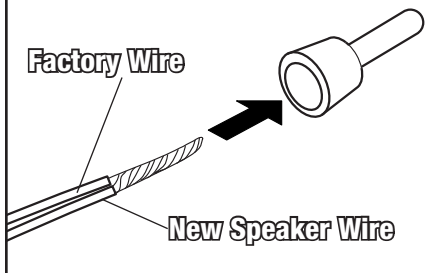

4. Squeeze middle of cap for tight connection.
5. Connect new wires to speaker with spade connectors.

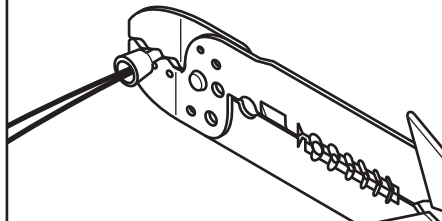

SOLDER METHOD

New speaker wires are spliced into factory wires behind harness.

1. Carefully strip out a 1/2" section on each factory speaker wire behind the factory speaker harness.

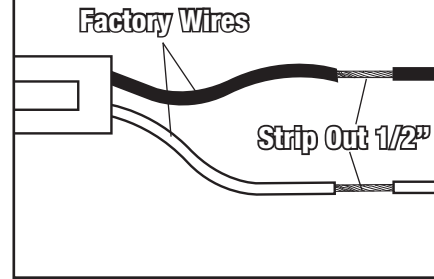

2. Twist wires from new speaker to stripped sections of factory wires as shown making sure polarity is correct.

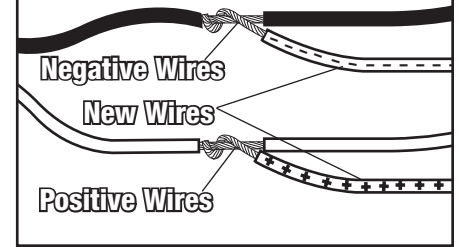

3. Heat wires first with soldering iron, then touch solder to wires for solid connections.

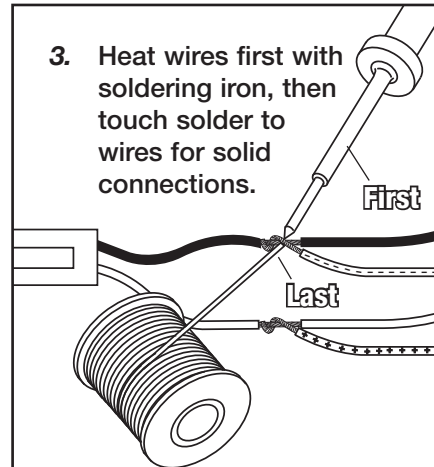

4. Wrap wiring connections with electrical tape.
5. Connect new wires to speaker with spade connectors.

