

PCV System

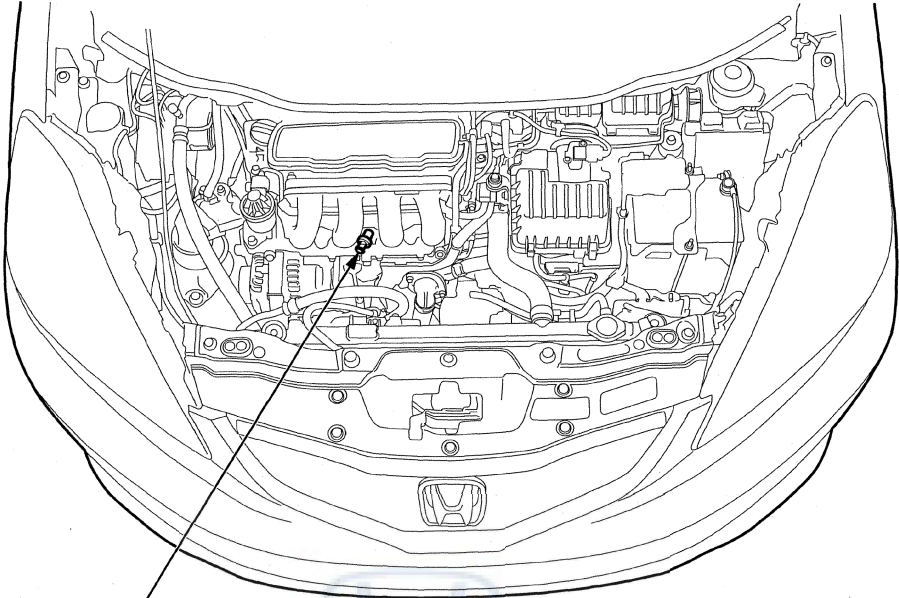

Component Location Index



PCV VALVE
Inspection, page 11-330
Replacement, page 11-330

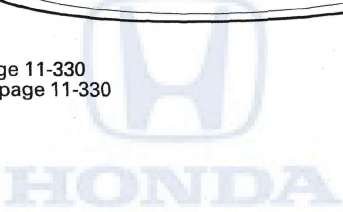

PCV System

PCV Valve Inspection

1. Remove the harness holder (A).

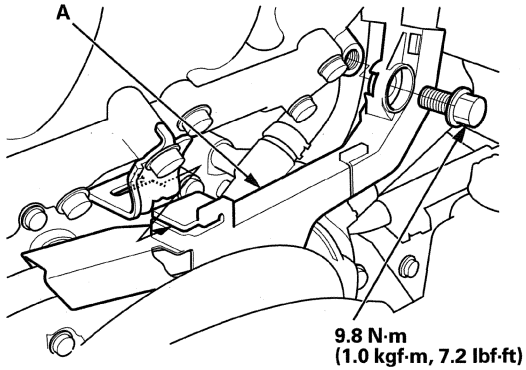

2. Check the PCV valve (A), the hoses (B), the pipe (C), and the connections for leaks or restrictions.

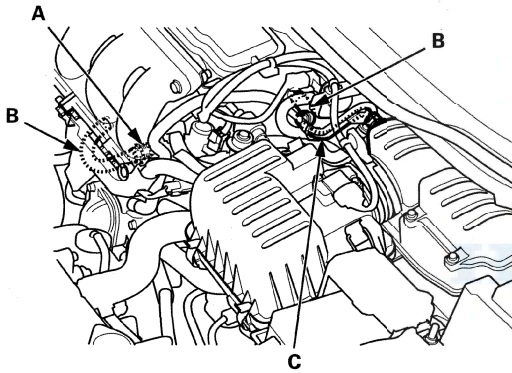

3. At idle, make sure there is a clicking sound from the PCV valve when the hose between the PCV valve and the intake manifold is lightly pinched (A) with your fingers or pliers.

If there is no clicking sound, check the PCV valve washer for cracks or damage. If the washer is OK, replace the PCV valve and recheck.

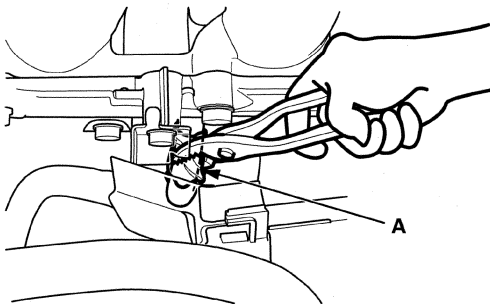

PCV Valve Replacement

1. Remove the harness holder (A).

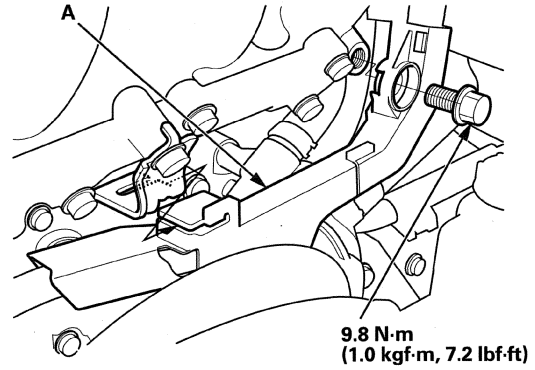

2. Disconnect the hose (A).

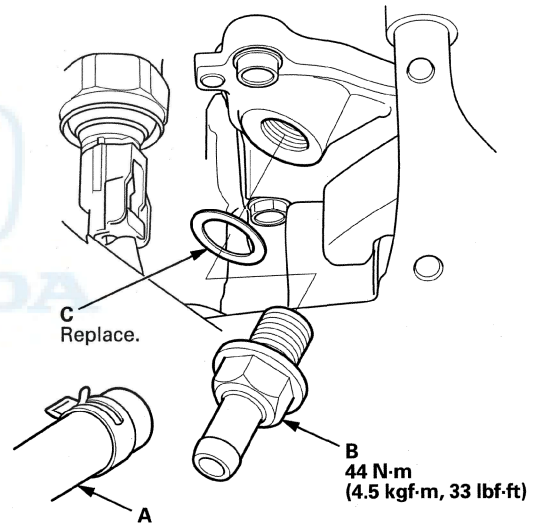

3. Remove the PCV valve (B).
4. Install the parts in the reverse order of removal with a new 14 mm washer (C).