

February 23, 2017

05899 Version 4

Engine Rattles at Cold Startup

(Supersedes 16-088 dated January 31, 2017 to revise the information highlighted in yellow)

AFFECTED VEHICLES

Year	Model	Trim	VIN Range
2015–16	Fit	ALL	ALL

REVISION SUMMARY

Under REPAIR PROCEDURE, step 23 was updated.

SYMPTOM

At cold start up, the engine rattles loudly for about 2 seconds. This may be intermittent and occurs on cold starts where the engine typically has not been started for 6–8 hours.

POSSIBLE CAUSES

The variable valve timing control (VTC) actuator is defective.

CORRECTIVE ACTION

Replace the VTC actuator. This procedure does not require the complete removal of the cam chain and associated parts, so repair time is shorter.

TOOL INFORMATION

Tool Name	Tool Number	Quantity
Stopper (Lock Pin)	14511-PNA-003	1
Tappet Adjuster	07MAA-PR70110	1
Tappet Lockout Wrench	07MAA-PR70120	1
Camshaft Holder Tool	07AAB-RWCA120	1

REQUIRED MATERIALS

Part Name	Part Number	Quantity
Honda Bond HT (One tube repairs 10 vehicles.)	08718-0004	1

CUSTOMER INFORMATION: The information in this bulletin is intended for use only by skilled technicians who have the proper tools, equipment, and training to correctly and safely maintain your vehicle. These procedures should not be attempted by “do-it-yourselfers,” and you should not assume this bulletin applies to your vehicle, or that your vehicle has the condition described. To determine whether this information applies, contact an authorized Honda automobile dealer.

PARTS INFORMATION

Part Name	Part Number	Quantity
VTC Actuator	14310-5R1-013	1
Fuel Joint Pipe Set	16012-5R1-315	1
O-Ring	91311-5R1-J01	1
Intake Manifold Gasket	17105-5R0-004	4
Throttle Body Gasket	17107-5R0-004	1
EGR Port Gasket	17108-5R0-004	1
Sealing Washer (12 mm)	16705-5R1-J01	2
Fuel High Pressure Pump Base O-Ring	91304-5R7-A01	1

WARRANTY CLAIM INFORMATION

The normal warranty applies.

NOTE: This procedure does not require the complete removal of the cam chain and associated parts, so repair time is shorter.

Operation Number	Description	Flat Rate Time	Defect Code	Symptom Code	Template ID	Failed Part Number
1101Z9	Replace the VTC actuator.	3.0 hrs	03214	04216	16-088A	14310-5R1-003

Skill Level: Repair Technician

DIAGNOSIS

If you are viewing this service bulletin on SIS and your computer has sound, click on the picture below to hear a sample of the engine's rattle.

1. Allow the engine oil to drain from the VTC system by not starting the engine for at least 6 hours.
2. Start the engine and immediately listen for a loud rattle.

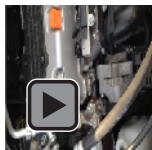

On start-up, do you hear a loud engine rattle that lasts about 2 seconds?

Yes – Go to REPAIR PROCEDURE

NO –

- If you hear a different noise, continue with normal troubleshooting.

If you do not hear an abnormal noise, get more information from the customer and, if needed, continue with normal troubleshooting.

REPAIR PROCEDURE

This procedure is in an outline form that you can also use as a checklist for the repair. If you need more details, refer to the service information for the following procedures:

- Intake Manifold Removal
- Cylinder Head Cover Removal
- Cylinder Head Cover Installation
- Intake Manifold Installation
- Valve Clearance Adjustment

- Relieve Fuel Pressure
1. Disconnect the negative battery cable.
 2. Remove the air cleaner assembly.
 3. Remove the throttle body, and move it to the side.
NOTE: Do not disconnect the coolant hoses.
 4. Remove the intake manifold.

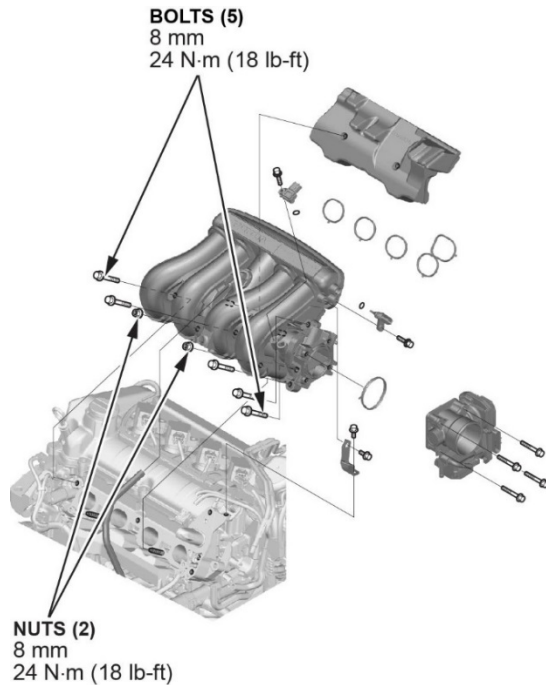

5. Remove the ignition coils.
6. Remove the cylinder head cover.

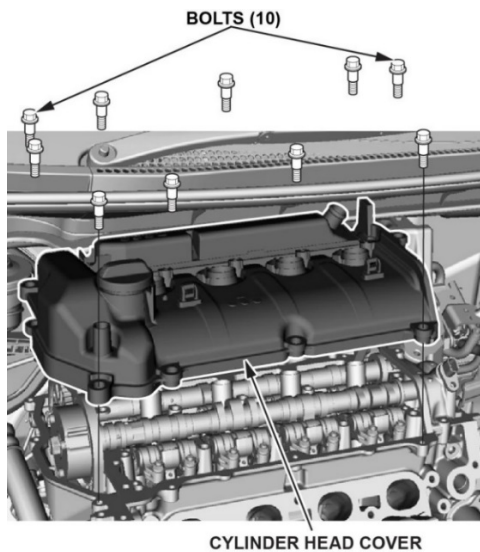

7. Rotate the crankshaft clockwise to TDC No. 1 cylinder.
 - Intake side – Mark the chain where the arrow on the VTC actuator is pointing to.
 - Exhaust side – Make a mark from the camshaft sprocket to the timing chain and secure the chain to the camshaft sprocket with zip ties.

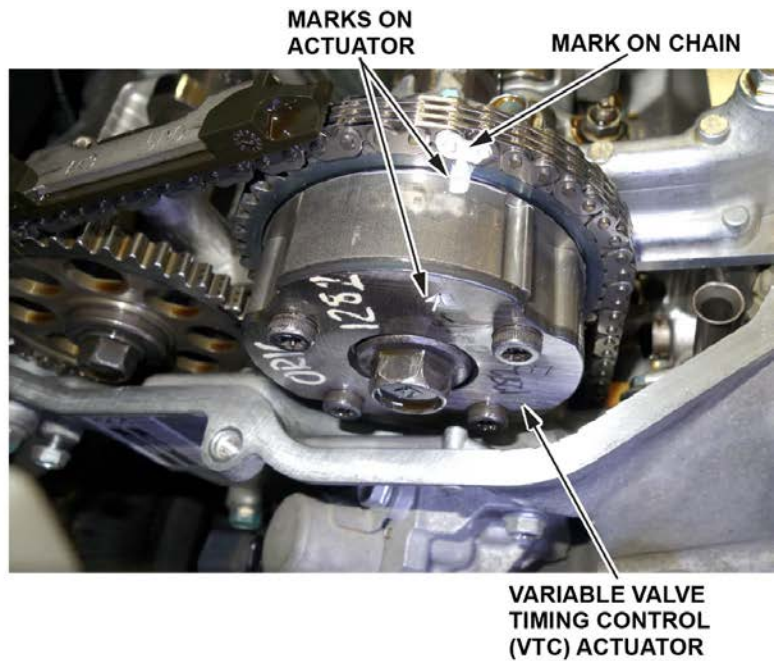
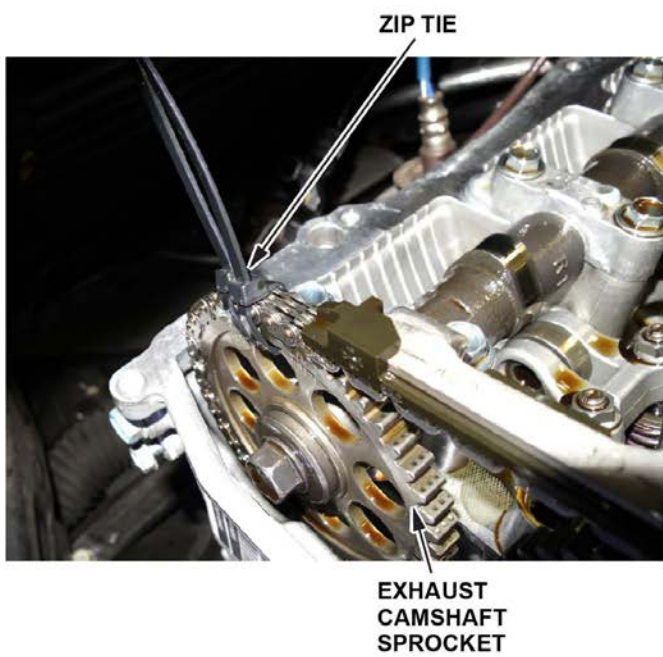
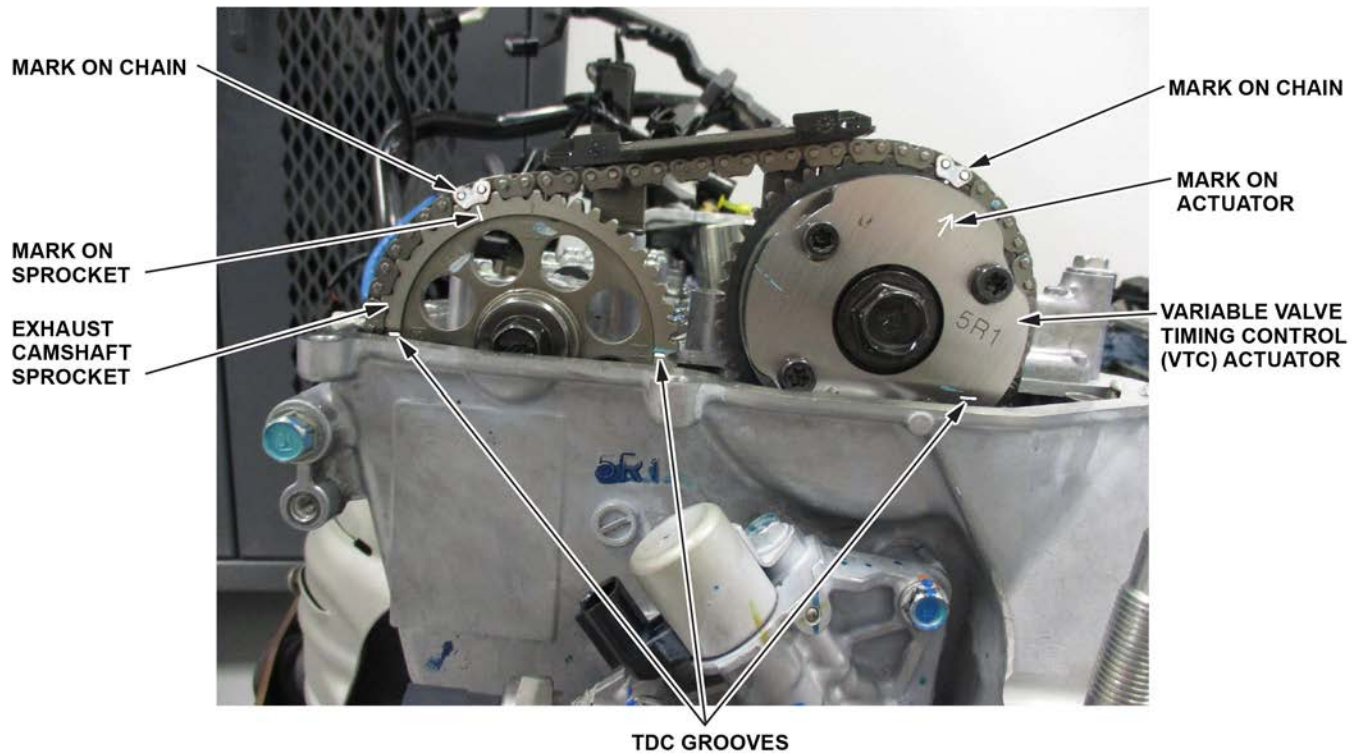

8. Remove the high-pressure fuel pump.
9. Remove the high-pressure fuel pump cover.

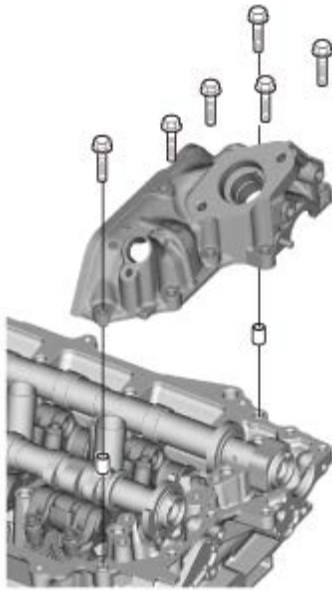

10. Raise the vehicle on a lift.
11. Remove the front right wheel.
12. Remove the right lower splash shield.
13. Remove the timing chain tensioner cover.
14. Slowly rotate the crankshaft counterclockwise a few degrees to compress the auto-tensioner. Align the hole in the lock and auto-tensioner, then insert a 1.2 mm (0.05 in.) diameter stopper (lock pin).

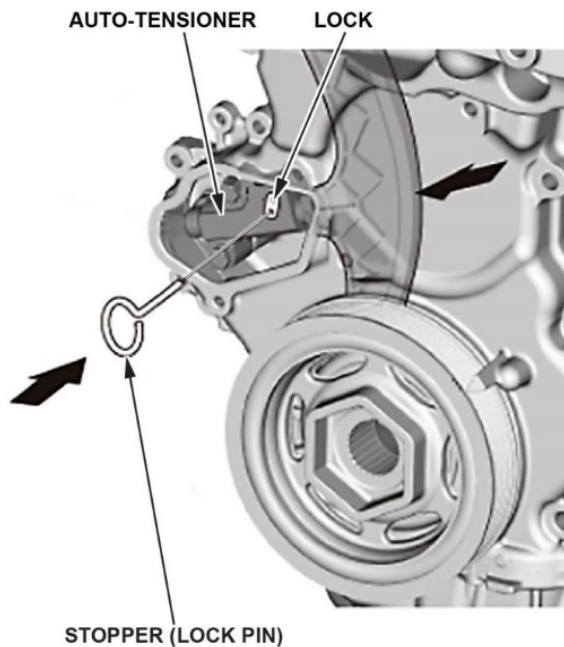

15. Slowly rotate the crankshaft clockwise back to TDC No. 1 cylinder.
16. Remove the timing chain tensioner.
17. Lower the vehicle.
18. Loosen the intake camshaft bearing cap bolts, in sequence, two turns at a time.
19. Remove the five intake side camshaft caps. Set them aside on a clean surface in the exact order and position that they were removed from the cylinder head.
20. Carefully tip up the end of the intake camshaft until there is enough slack for an assistant to lift the chain off the VTC actuator teeth.

21. Remove the intake camshaft/VTC actuator assembly while the assistant keeps light tension on the chain. Place the camshaft/VTC actuator assembly on a clean, padded workbench.
22. Secure the timing chain with a bungee cord to keep it from falling into the front cover.



23. On the workbench, as an assistant holds the camshaft steady with an open-end wrench, remove the VTC actuator mounting bolt, then separate the VTC actuator from the camshaft. **Do not reuse the original VTC actuator.**



24. Install the new VTC actuator onto the camshaft; do not force it on.
25. Once fitted, carefully rotate the VTC actuator until it engages the camshaft's locator pin. Apply clean engine oil to the mounting bolt threads, then install the mounting bolt, finger tight.

26. Have an assistant hold the camshaft/VTC actuator assembly steady on the padded workbench with an open-end wrench. Use a torque wrench to torque the mounting bolt to **115 N·m (85 lb-ft)**.

NOTE: Be careful not to scratch or damage the camshaft. Also, do not use an impact wrench to tighten the mounting bolt; it will cause internal damage to the VTC actuator housing, vanes, or lockpin.

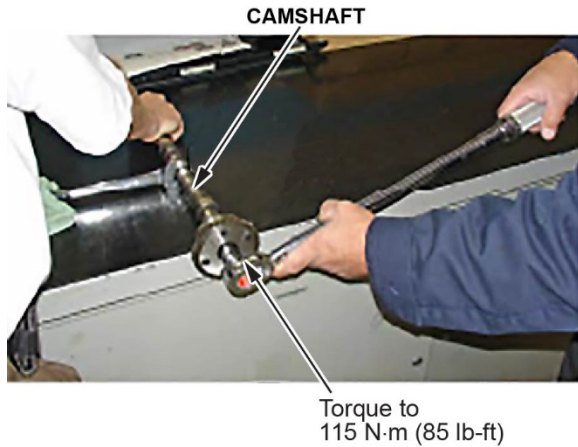

27. Remove the bungee cord as an assistant keeps light tension on the chain.
28. Slide the camshaft/VTC actuator in at an angle so that the chain can slip over the actuator's teeth.
29. Line up the arrow on the new VTC actuator with the mark made previously on the chain.



30. Apply engine oil to the camshaft journals and caps. Lower the camshaft/VTC actuator assembly onto its journals.

31. Install the camshaft holders, torque them in 2 steps. On the first step, start in the middle and work your way outward, torquing the bolts to **5 N·m (4 lb-ft)**. On the second and final step, torque the bolts to **13 N·m (10 lb-ft)** starting in the middle and working your way outward.

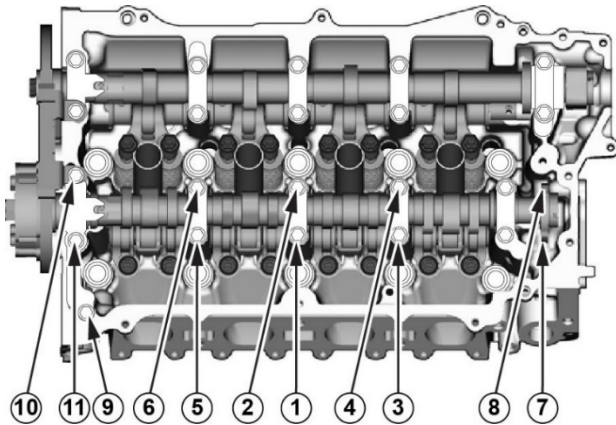

32. Install the timing chain auto-tensioner, and torque it to **12 N·m (9 lb-ft)** then, remove the lock pin from the auto-tensioner.
33. Remove the zip ties holding the timing chain and exhaust camshaft sprocket in place. Make sure no debris drops in between the timing chain cover.
34. Rotate the crankshaft in the direction of engine rotation (clockwise) two full turns, then stop at the TDC mark on the crank pulley. Make sure all three TDC grooves on the camshaft sprocket and actuator lines up with the front cover.

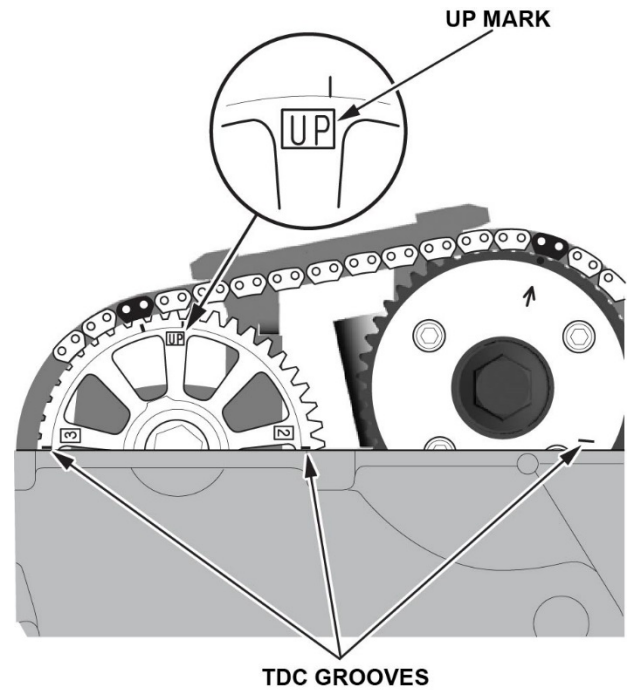

35. Make sure the camshaft maintenance hole lines up with the upper camshaft holder groove. If the marks are not lined up, rotate the crankshaft two full turns, and recheck the camshaft pulley mark.

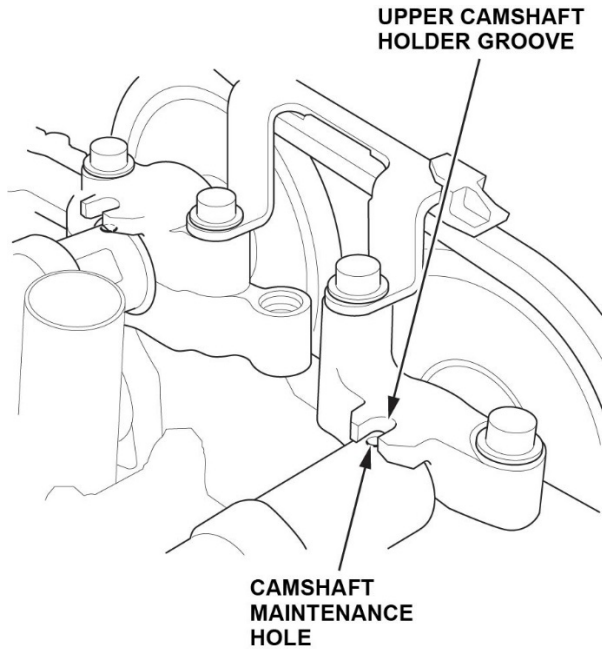

36. Inside the cylinder block, visually confirm that the timing chain is properly riding on its guide, and has not slipped behind the guide in the block. If so, realign the chain as needed and recheck the timing.
37. Remove the old sealant from the auto-tensioner cover, then dry and seal it. Install the cover and torque it to **12 N·m (9 lb-ft)**.

NOTE: Wait 30 minutes before adding oil, (if needed), then wait 3 hours before starting the engine.

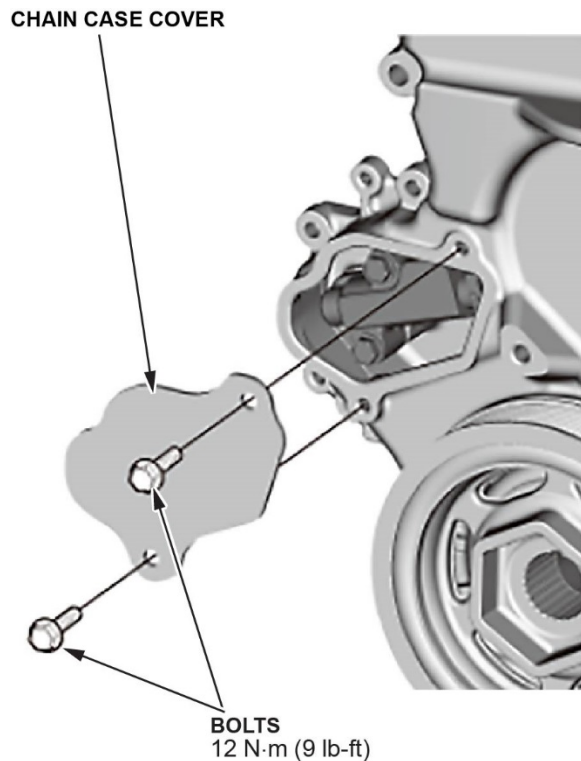

38. Remove all of the old liquid gasket from the cylinder head and the high-pressure fuel pump cover.
39. Apply liquid gasket on the cylinder head and the high-pressure fuel pump cover mating areas. Install the cover within 5 minutes of applying the liquid gasket.

NOTE:

- Apply a 2.5 mm (0.098 in) diameter bead of liquid gasket along the broken line.
- If too much time has passed after applying the liquid gasket, remove the old liquid gasket and residue, then reapply new liquid gasket.

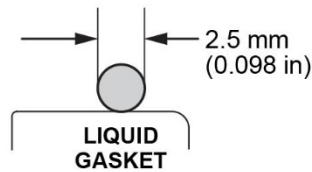
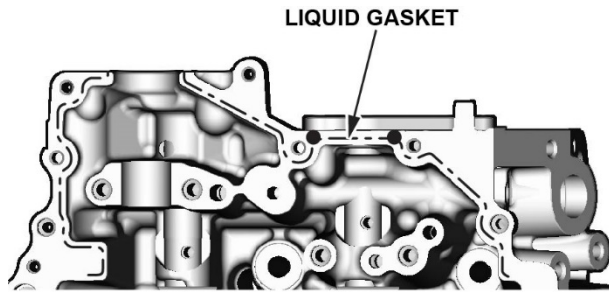

40. Install the high-pressure fuel pump cover, and torque it to **12 N·m (9 lb-ft)**.

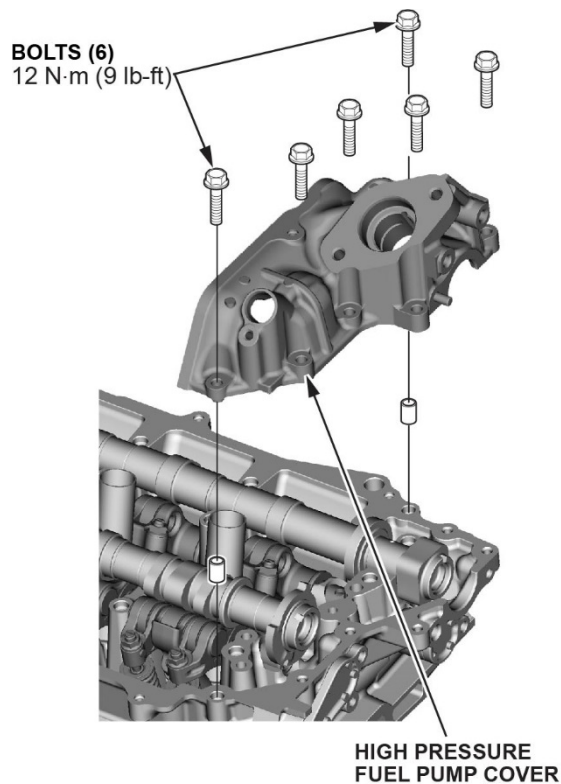

41. Install the new fuel pipe and high-pressure fuel pump.

42. Check the valve clearance using a tappet adjuster.

Intake: 0.21 – 0.25 mm (0.008 – 0.010 in.)

Exhaust: 0.25 – 0.29 mm (0.010 – 0.011 in.)

43. Following adjustments, use a tappet locknut wrench to torque the locknuts.

Intake and Exhaust: 14 N·m (10 lb-ft)

44. Install the remaining removed parts in reverse order.

END